

MO42 Molybdate Analyzer

Features and Benefits

Reliable and Economical Molybdate Analysis

The Hach MO42 Molybdate Analyzer uses colorimetric catechol chemistry to continuously monitor a sample stream for molybdate content. This process analyzer is a dependable and economical alternative to costly, time-consuming laboratory analysis methods.

Manual or Automatic Feed Pump Control

Chemical feed can be manually or automatically controlled by either the alarm relay contacts or the proportional 4-20 mA recorder output. When set for manual control, the instrument notifies the operator of out-of-limit molybdate levels for manual intervention in the process as needed. For automatic control of molybdate feed pumps, the MO42 analyzer can use one of two methods:

- 1. On-Off Control**—turns the feed pumps on when molybdate levels fall too low for sample treatment and off when levels rise above a pre-set limit.
- 2. Proportional Control**—adjusts the amount of molybdate in proportion to the signal level of the MO42 analyzer's output.

Simple Maintenance

Routine maintenance can typically be performed monthly in 15 minutes because the sample cell and pre-filter are easy to clean and the case provides quick access. (Difficult samples, i.e. turbid or oily samples, may require more frequent cleaning.) The MO42 analyzer is also equipped with self-testing diagnostics to make troubleshooting easy.

Method of Analysis

Available molybdenum ions react with pyrocatechol (catechol) at buffered pH to form a yellow colored complex compound. After the chemical reaction is complete, the optical density (absorbance) at 420 nm is compared to the absorbance of the sample measured before the reagent was added. The depth of intensity of the resulting color is proportional to the concentration of molybdenum in the sample, which is calculated from the difference in absorbance values.



The Hach MO42 Molybdate Analyzer uses fast, reliable, and economical catechol chemistry for up to 30 days of unattended operation. No extensive maintenance and minimal use of reagents means low operating costs.

IW

Applications - Industrial

The MO42 Molybdate Analyzer is ideal for industrial water treatment applications where it is necessary to continuously monitor and control the concentration of molybdate within specified levels—cooling towers and closed recirculating systems, such as hot water heating (boilers) and chilled water systems (coolers). Molybdate compounds are used extensively in these areas as corrosion inhibitors or as tracer agents for the determination of concentrations of other treatment chemicals. It is important that the concentration of molybdate be maintained at the specified levels in order to balance the benefits of corrosion protection without the additional expenses of chemical overfeed. The Hach MO42 Molybdate Analyzer is an effective alternative to laboratory methods for molybdate monitoring and allows for real time feed control.

DW = drinking water WW = wastewater municipal PW = pure water / power
IW = industrial water E = environmental C = collections FB = food and beverage



Be Right™

Specifications*

Range

0 to 5 mg/L as Mo⁶⁺

Accuracy

±5% or ±0.05 mg/L as Mo⁶⁺, whichever is greater

Precision

±3% or 0.03 mg/L as Mo⁶⁺, whichever is greater

Minimum Detection Limit

0.03 mg/L

Cycle Time

2.5 minutes

Inlet Pressure to Instrument

1 to 5 psig (1.5 psig is optimum)

Inlet Pressure to Sample Conditioning

1.5 to 75 psig

Air Purge (optional)

0.1 cfm instrument quality air at 20 psig maximum

Sample Flow

200 to 500 mL per minute minimum required

Sample Temperature

5 to 40°C (41 to 104°F)

If sample temperature is consistently outside of the range of 15 to 30°C, instrument may require calibration in the temperature range of operation.

Operating Temperature

5 to 40°C (41 to 104°F)

Operating Humidity

90% at 40°C (90% at 104°F) maximum

Interferences

Excessive concentrations of copper and iron (III) ions (>0.5 ppm) especially in conjunction with high alkalinity (>600 ppm) might cause interference outside the specified accuracy.

Recorder Outputs

One 4-20 mA with an output span programmable over any portion of the 0 to 5 mg/L range, 130 V isolation from earth ground, 500 ohm maximum

One isolated recorder output, 4-20 mA (can be adjusted to 0-20 mA), recommended load impedance 3.6 to 500 ohms. Optional AquaTrend® Network interface

Alarm Relay Outputs

Two alarms selectable for sample concentration alarm, analyzer system warning, or analyzer system shut-down alarm. Each is equipped with an SPDT relay with contacts rated for 5A resistive load at 230 Vac.

Sample Inlet Connection

1/4-inch OD polyethylene tube, quick-disconnect fitting

Drain Connection

1/2-inch ID flexible hose, hose barb

Air Purge (optional)

1/4-inch OD tube, quick-disconnect fitting, 0.1 cfm instrument quality air at 20 psig maximum

Certification

CE approved

ETL listed to UL 1262

ETL certified to CSA 22.2 No. 142

Enclosure

ABS plastic, two clear polycarbonate windows, IP62-rated with the gasketed door latched

Mounting

Wall mount

Display

LCD, 3-digit measurement readout and six-character alphanumeric scrolling text line

Light Source

Class 1 LED (light emitting diode) with a peak wavelength of 428 nm; 50,000 hours estimated minimum life.

Power

100 to 115/230 Vac, 50/60 Hz (switch selectable), 95 VA maximum, 2.5 Amp fuse

Dimensions

34.3 x 41.9 x 19.1 cm (13.5 x 16.5 x 7.5 in.)

Shipping Weight

11.3 kg (25 lbs.)

**Specifications subject to change without notice.*

Engineering Specifications

- The molybdate analyzer shall employ a catechol colorimetric method of measurement using catechol reagent solution drawn from two bottles simultaneously.
- A measurement shall be taken every 2.5 minutes and results displayed by a three digit LCD readout in the range of 0 to 5 mg/L.
- The analyzer shall be designed for 30-days unattended operation and use only 500 mL of each reagent per month.
- The analyzer shall operate with an LED light source with a peak wavelength of 428 nm.
- The instrument shall measure a sample blank before each sample measurement to provide automatic zero reference to compensate for sample color and turbidity and changes in light intensity due to light source aging.

Continued on next page.

Engineering Specifications *continued*

6. The instrument shall provide a minimum detection limit of 0.03 mg/L or better, precision better than $\pm 3\%$ or 0.03 mg/L as Mo^{6+} , and accuracy better than $\pm 5\%$ or 0.05 mg/L as Mo^{6+} .
7. The analyzer shall be microprocessor-controlled and provide a 4-20 mA recorder output as well as 2 alarm relay contacts.
8. Each alarm shall be user-selectable for sample concentration alarms (high or low), analyzer system warnings, or analyzer system shutdown alarms.
9. The sample concentration alarms shall be fully adjustable through the entire range.
10. The system warning shall activate for minor variations in analyzer performance.
11. A system alarm shall activate for major variations in analyzer performance and it shall shut down the analyzer until corrective action is taken.
12. The microprocessor shall provide self-diagnostic functions accessible through an alphanumeric, menu-driven keyboard.
13. Two SPDT normally open/normally closed dry contact relays rated at 5A resistive load at 230 Vac shall be provided.
14. Recorder outputs shall be 4-20 mA.
15. Recorder span minimum and maximum values shall be operator programmable at the menu-driven keypad over the entire operating range.
16. The molybdate analyzer shall be housed in an IP-62 rated, ABS plastic enclosure designed for wall mounting.
17. The enclosure shall have two clear polycarbonate windows for viewing the measurement readout and reagent levels.
18. Power requirements shall be 100-115/230 Vac, 50/60 Hz, switch selectable, 95 VA maximum.
19. The instrument shall be the Model MO42 Molybdate Analyzer, manufactured by Hach Company.

Dimensions

The Hach MO42 Molybdate Analyzer is designed to be wall-mounted with four 1/4-inch screws. Adequate clearance must be left at the sides and bottom of the case for plumbing and electrical connections. The sample inlet connection is 1/4-inch quick-disconnect fitting and the drain connection is 1/2-inch ID flexible hose. Electrical connections are inside the instrument case. Holes for three 1/2-inch conduit fittings are provided.

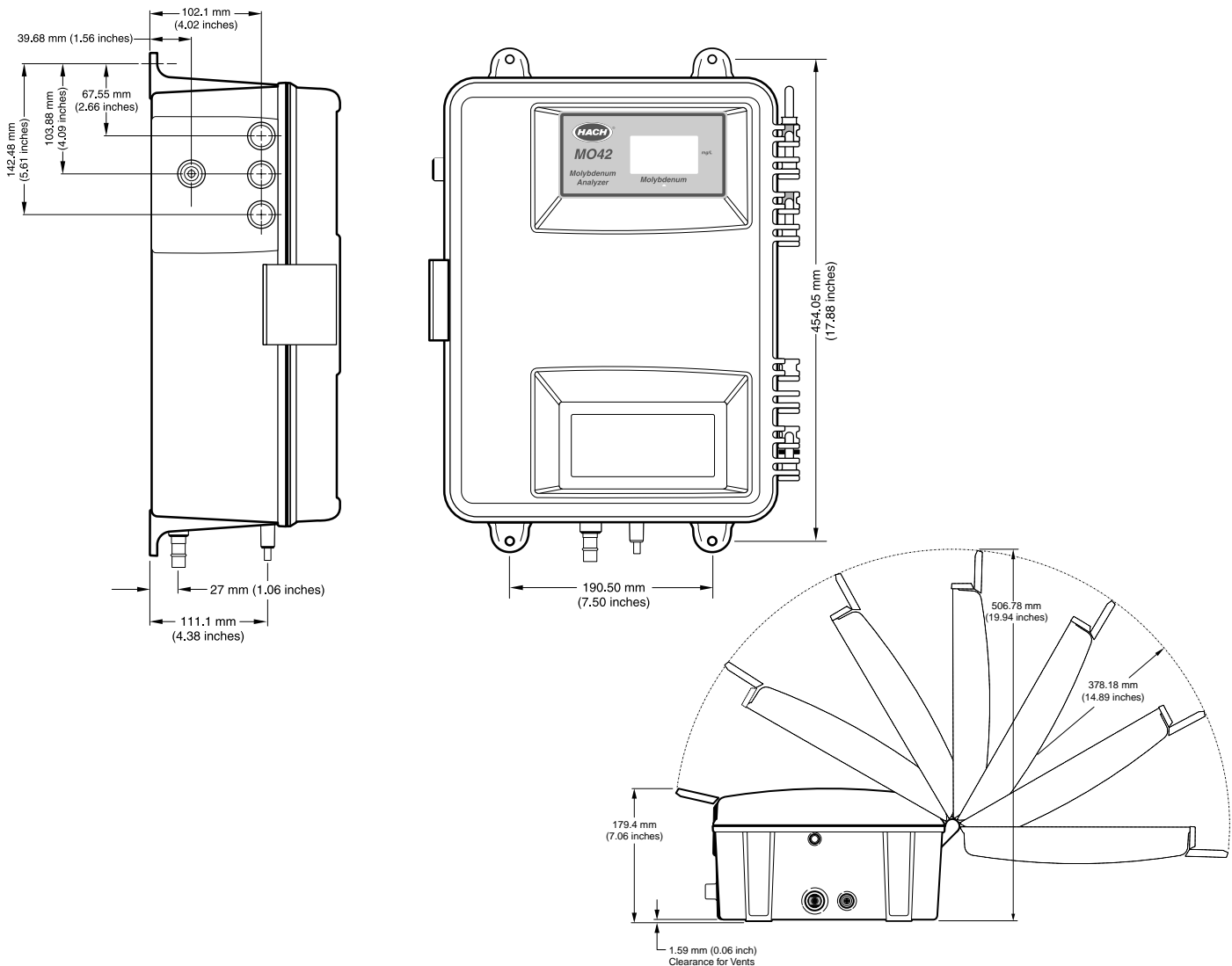

Principle of Operation

The Hach MO42 Molybdate Analyzer is composed of a linear peristaltic pump to precisely control the volume of incoming sample and reagent and a colorimeter with seal-free, solid-state mixing system that includes a self-cleaning stir bar.

A zero reference point is established with the first sample in the cycle by measuring blank absorbance. This compensates for the sample's color intensity and turbidity before the molybdate measurement is made. Reagent is then added to the sample as it is stirred and the sample changes color. The colorimeter then measures the light transmitted through the sample and the measured color intensity is compared to the internally stored calibration curve. Finally, the sample cell is flushed with new sample so that the cycle can repeat itself every 2.5 minutes.

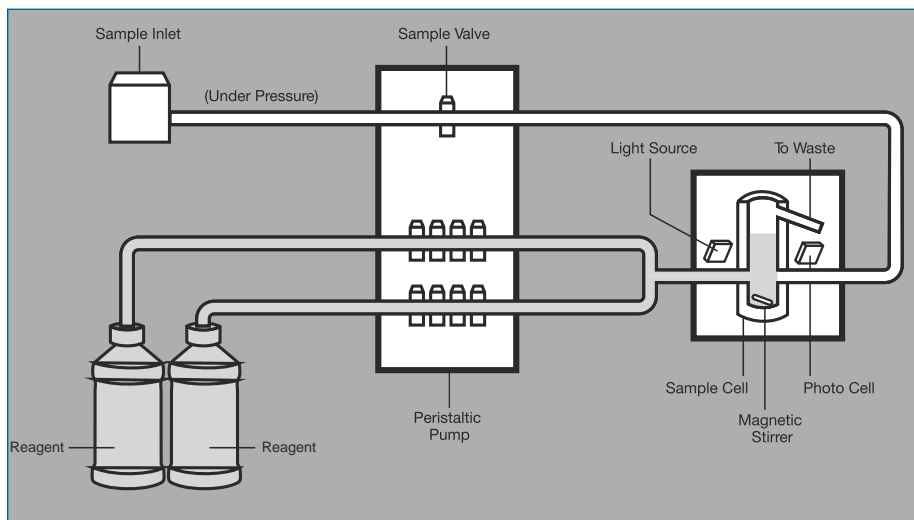

At Hach, it's about learning from our customers and providing the right answers. It's more than ensuring the quality of water—it's about ensuring the quality of life. When it comes to the things that touch our lives...

Keep it pure.

Make it simple.

Be right.

For current price information, technical support, and ordering assistance, contact the Hach office or distributor serving your area.

In the United States, contact:

HACH COMPANY World Headquarters
P.O. Box 389
Loveland, Colorado 80539-0389
U.S.A.
Telephone: 800-227-4224
Fax: 970-669-2932
E-mail: orders@hach.com
www.hach.com

U.S. exporters and customers in Canada, Latin America, sub-Saharan Africa, Asia, and Australia/New Zealand, contact:

HACH COMPANY World Headquarters
P.O. Box 389
Loveland, Colorado 80539-0389
U.S.A.
Telephone: 970-669-3050
Fax: 970-461-3939
E-mail: intl@hach.com
www.hach.com

In Europe, the Middle East, and Mediterranean Africa, contact:

HACH LANGE GmbH
Willstätterstraße 11
D-40549 Düsseldorf
GERMANY
Tel: +49 (0) 211 5288-0
Fax: +49 (0) 211 5288-143
E-mail: info@hach-lange.de
www.hach-lange.com

Ordering Information

Hach MO42 Molybdate Analyzers include a one-month supply of reagents, maintenance kit, installation kit, and user manual. (Power cord sold separately.)

6180004 Hach MO42 Molybdate Analyzer

Accessories

5448800 Power Cord; 125V, 10A, 1.83 m (6 ft.)

5448900 Power Cord; 230V, 10A, 1.83 m (6 ft.), continental European plug

6181100 Maintenance Kit; 1 year, includes tubing, caps, funnel, and fittings

6181101 Maintenance Kit with Preassembled Tubing; 1 year, includes tubing, caps, funnel, and fittings

4643600 Flow Meter; with 1/4-inch OD tubing

Reagents

The Hach MO42 Molybdate Analyzer requires two (2) 500 mL bottles of reagent for a 30-day operating period.

2890549 MO42 Reagent, 500 mL

Lit. No. 2589

G7X Printed in U.S.A.

©Hach Company, 2007. All rights reserved.

In the interest of improving and updating its equipment, Hach Company reserves the right to alter specifications to equipment at any time.



Be Right™